

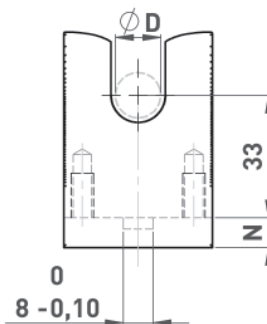

Former Fab®

uForm

Beutelbreite 13-28

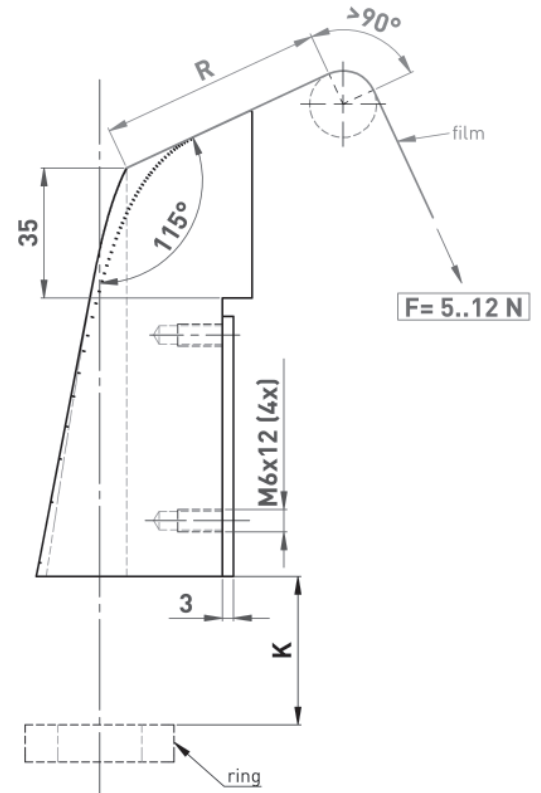
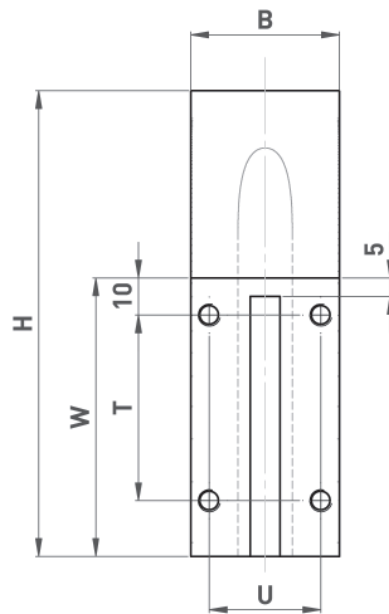
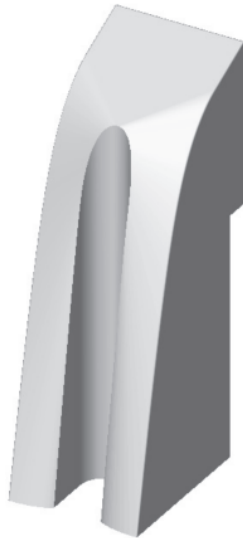

Materialoptionen:

- * Edelstahl (1.4301 / AISI 304)
- * Aluminium (EN AW-6082),
Oberfläche hartanodisiert und
imprägniert mit PTFE

uForm			13-17	18-21	22-24	25-28
Beutelbreite		mm	13..17	18..21	22..24	25..28
Folienbreite		mm	32..46	41..59	51..66	57..72
Formrohrdurchmesser D	D	mm	8..10	11..13	14..15	16..17
Breite	B	mm	30	40	50	56
Gesamthöhe	H	mm	119	125	135	145
Rückseitiger Überstand	N	mm	3	8	8	8
Abstand Einlaufrolle	R	mm	35	35	35	40
Abstand Gewindebohrungen	T	mm	50	50	50	50
Abstand Gewindebohrungen	U	mm	20	30	30	30
Abstand Auflegekante	W	mm	70	75	85	95
Empfohlener Abstand zum Ring	K	mm	70	70	80	80



Former Fab®

uForm

Beutelbreite 29-42

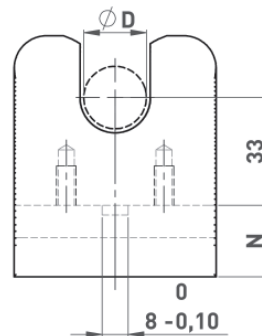
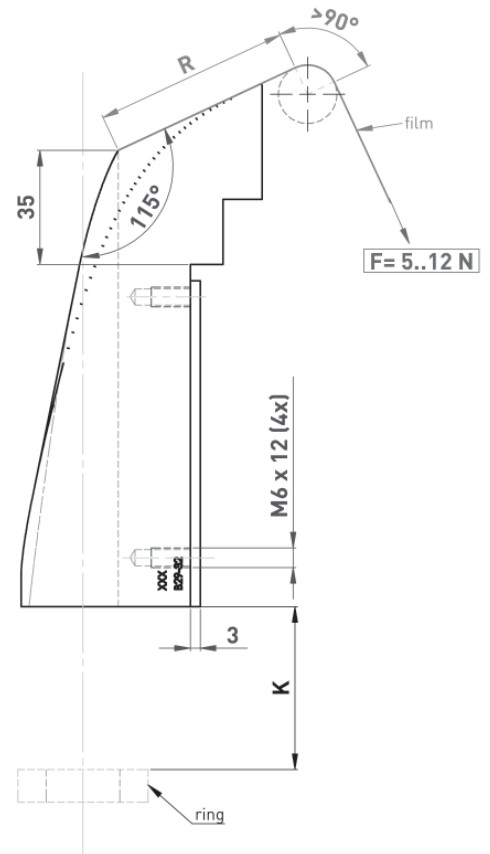
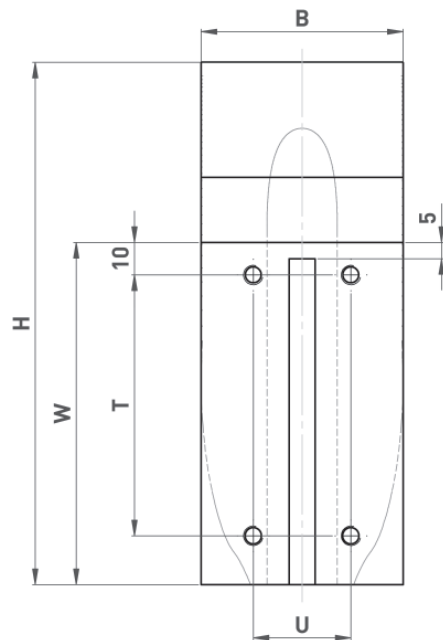
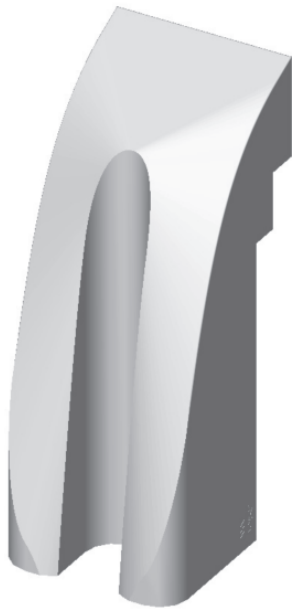

Materialoptionen:

- * Edelstahl (1.4301 / AISI 304)
- * Aluminium (EN AW-6082),
Oberfläche hartanodisiert und
imprägniert mit PTFE

uForm			29-32	33-35	36-39	38-42
Beutelbreite		mm	29..32	33..35	36..39	38..42
Folienbreite		mm	63..81	73..88	79..94	82..100
Formrohrdurchmesser D	D	mm	18..20	21..22	23..24	24..26
Breite	B	mm	62	72	78	78
Gesamthöhe	H	mm	160	164	173	194
Rückseitiger Überstand	N	mm	22	31	51	44
Abstand Einlaufrolle	R	mm	60	70	90	100
Abstand Gewindebohrungen	T	mm	80	80	80	80
Abstand Gewindebohrungen	U	mm	30	30	30	30
Abstand Auflegekante	W	mm	105	105	105	130
Empfohlener Abstand zum Ring	K	mm	80	90	90	90